

Thermal-structural FEM Simulations in an Aero-Structures Design Course

Alan Zehnder

Course taught in collaboration with

Tony Ingraffea

Cornell University

and

Barry Davidson

Syracuse University



Cornell University



Presented at **ISTEC 2008**

Integration of Simulation Technology into the Engineering Curriculum,
July 25-26, 2008

Supported by NASA Langley Research Center through Cooperative Agreement No. NCC-1-01004, the AT&T Foundation, the State of New York, Syracuse and Cornell Universities.

Project Context

- Cornell / Syracuse course “Collaborative Engineering Design” (senior capstone)
- Student teams (3 CU & 3 SU) perform preliminary thermal-structural design of sections of a re-entry vehicle
- Emphasis on
 - *Aerospace structural analysis and design*
 - *Thermal analysis and design*
 - *Both of the above included analytical calculations and finite element simulations*
 - Team work
 - Presentation skills
 - How to work in a “virtual team”
- Class meetings held via laptop computer based videoconferencing & application sharing
- Each student (and instructor) are in physically separate locations (could be anywhere).

Design Assignment - Fall 2006

- Preliminary thermal protection system (TPS) and structural system design for Crew Vehicle
- 10 loading cases
- Re-entry and launch heating
- Structural material (i.e. Al-Li Ti-6-4,...) assigned
- Structural and TPS configuration constrained to a given conceptual design

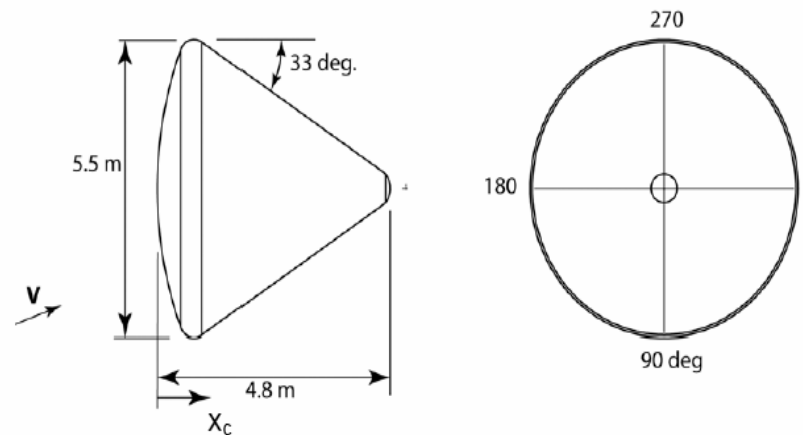

Technical Expectations

- Deliver and present summary report containing:
 - Design drawings
 - Show correspondence of closed-form and FEM methods of analysis
 - Assess manufacturability, cost, risk and *weight*
 - Design must withstand given mechanical and thermal loads within specified safety factors.
 - Material strength, structural stability, maximum allowable material temperatures. Assess micrometeorite damage resistance, ...

FEM in Course Preparation

- Tutorials on shell analysis in Ansys, developed with Raj Bhaskaran, emphasizing parametric modeling and validation of FEM against closed-form analyses.
- Extensive test runs checked against closed-form methods both to check FEM results and to select analytical approximations that we can then teach to the students. For example:
 - When must shear deformation be considered?
 - How should stiffnesses be computed for a built-up structure?
- Prototype FEA analyses performed and used to develop lecture notes for:
 - Stress and deflection of built-up plate under pressure, in-plane and thermal loads
 - Global and local buckling
 - Transient heat conduction

FEM Instruction in Course - I

- $\frac{1}{2}$ of students studied FEM, other $\frac{1}{2}$ analytical methods
- Two lectures on FEM basics using truss and plane stress problems as examples
 - Sources of approximation?
 - What is a shape function?
 - Principle of virtual displacements
 - Assembling the equations
 - Solution and compare to analytical result
 - How to assess if solution is accurate
 - Use of consistent units
- Used Cornell ANSYS Tutorials developed by Raj Bhaskaran
- Students asked to work truss and plane-stress tutorial problems.

FEM Instruction in Course - II

- Three FEM application lectures
 - Shell problems, buckling, introduction to parametric modeling, use of symmetry
 - Thermal analysis in ANSYS
 - Building up shell model parametrically
- Each lecture ends with an assignment to build and solve model problems similar to those needed for design.
- How to apply given mechanical and thermal loads, how to compare simple models to analytical results and interpretation of FEM results are emphasized.

Example Slide from Lectures: 1D Transient Thermal Analysis

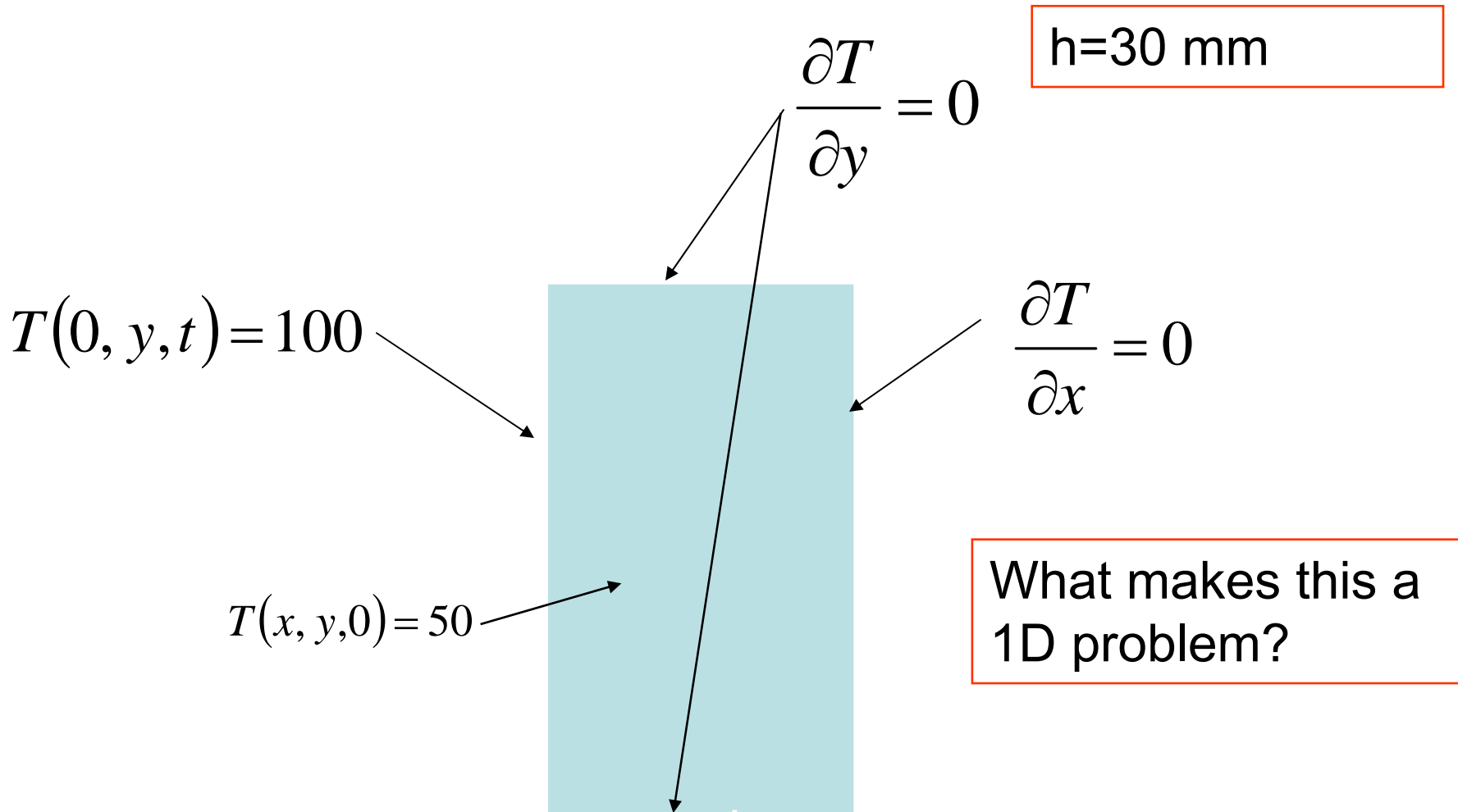

Example of Material Provided to Students:

Steps in the setup and solution of ANSYS Model

- Preferences – Thermal Analysis
- Plane77, 2D thermal solid element, no real constants
- Specify thermal properties (stick with SI units) If you use length in mm you need to convert the thermal properties to base units in mm.
 - Density: $1000 \text{ kg/m}^3 = 1\text{e-}6 \text{ kg/mm}^3$
 - Specific heat: $1000 \text{ J/kg K} = 1\text{e+}9 \text{ mm}^2/\text{s}^2 \text{ K}$
 - Conductivity: $1 \text{ W/m k} = 1000 \text{ kg mm/s}$
- Specify transient analysis
 - Give max. temperature, max. time step (see load step options and analysis options) Can select program chosen for most options. Generally gives good results.
 - Save results at each substep (see solution controls)
- Specify initial and boundary conditions
 - Zero heat flux boundaries
 - Specified temperature boundary
 - Temperature at all nodes set to initial temperature
- Solve LS and then view results
 - Use results viewer to easily scroll through different time steps
 - Time history viewer will let you plot or export data for the time variation of a solution variable (nodal temperature in this case) at a chosen node. Pick node using GUI.
- Setup, run and post-process model during class time.

- The above is provided to students ahead of time.
- They are expected to read it
- During class, instructor works through problem discussing what is being done, taking questions and discussing results
- Class session is recorded for students who wish to replay the lecture

Emphasize checking FEA results against theory:

Temperature from FEM and analytical solutions at $t=1200$ sec.

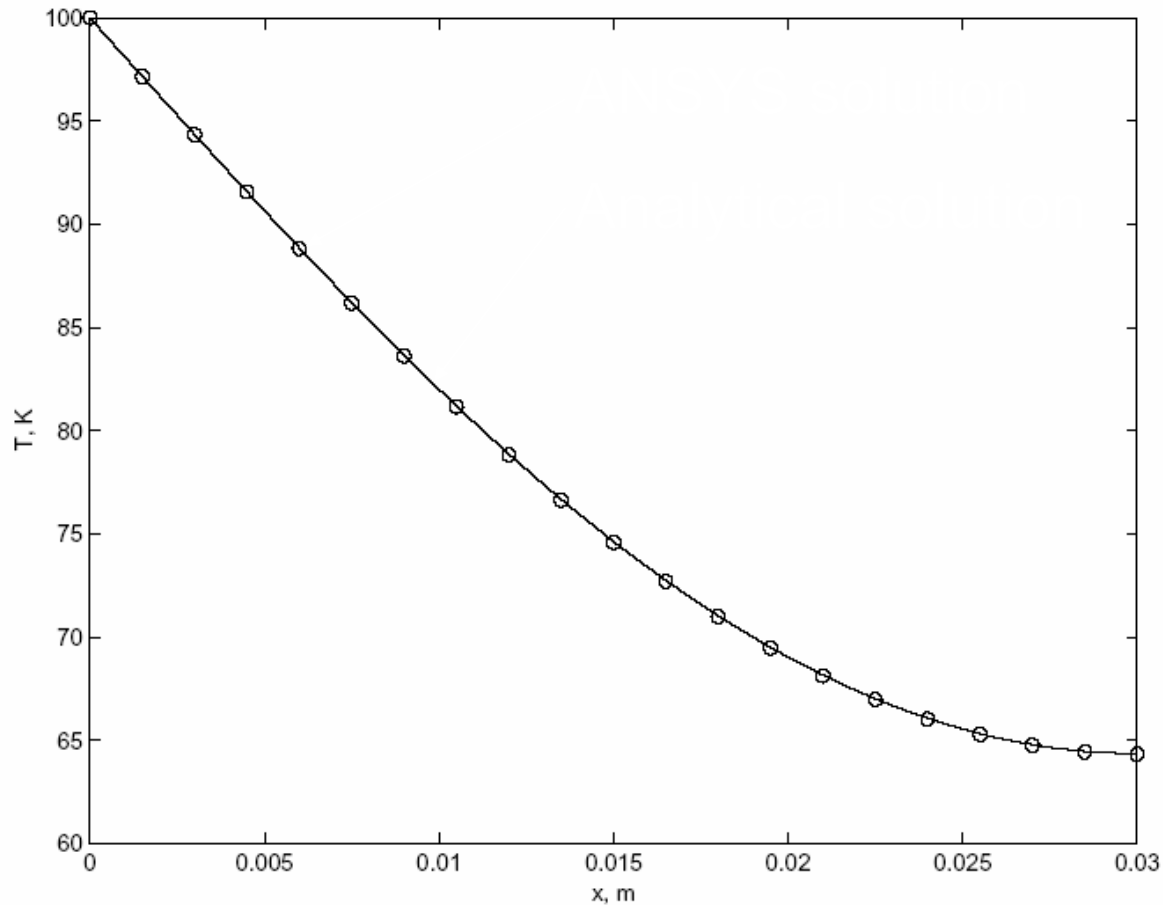

Student Use of FEM in Design

- Teams generally split up the work so that one member worked on thermal analysis, two on structural analysis, often considering two concepts.
- Teams successful with basic thermal, stress and deflection analyses.
- Most groups were not able to accurately perform the more difficult analysis, such as buckling and stress due to thermal gradients.

Sample Student Work: Design Concept

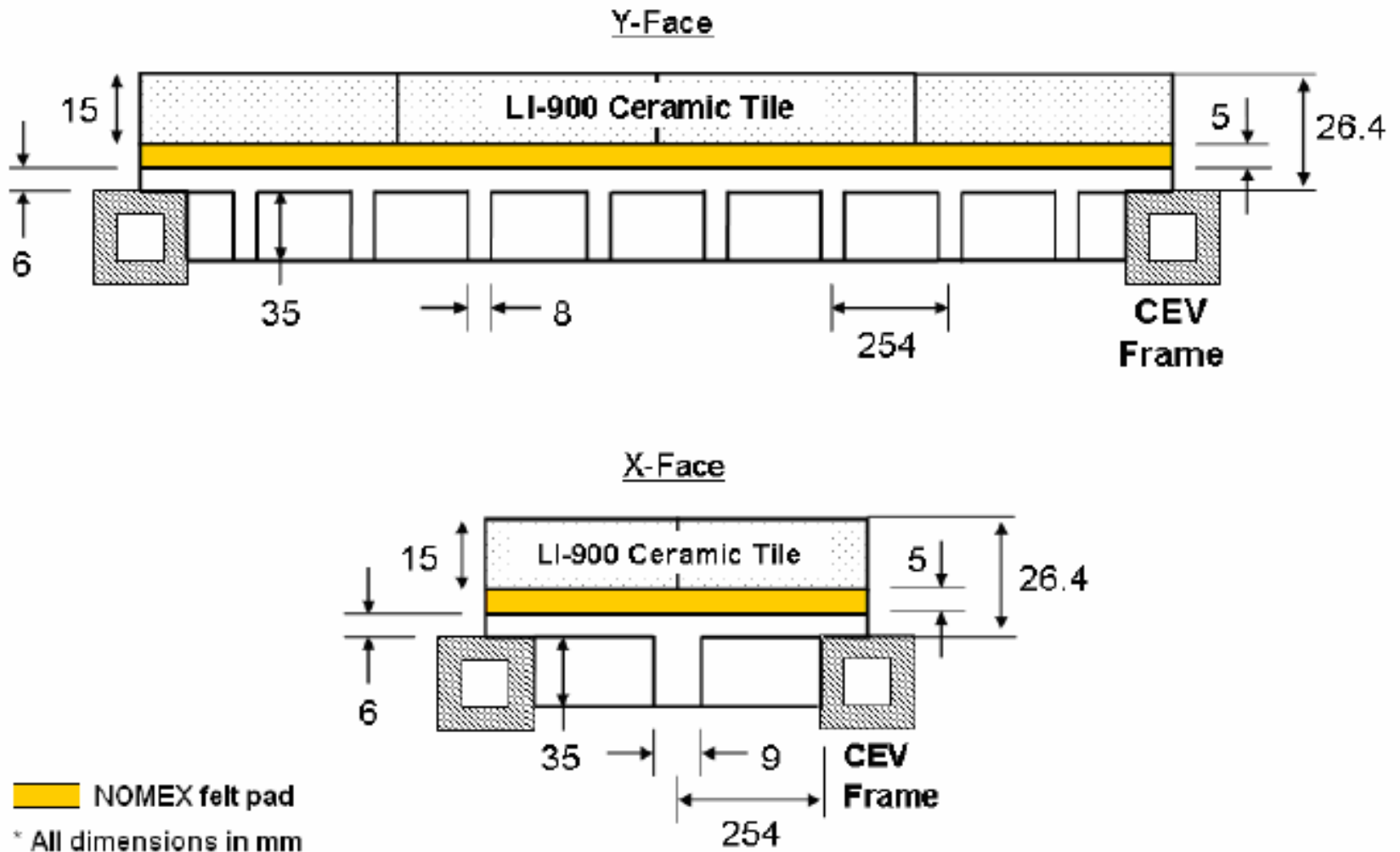
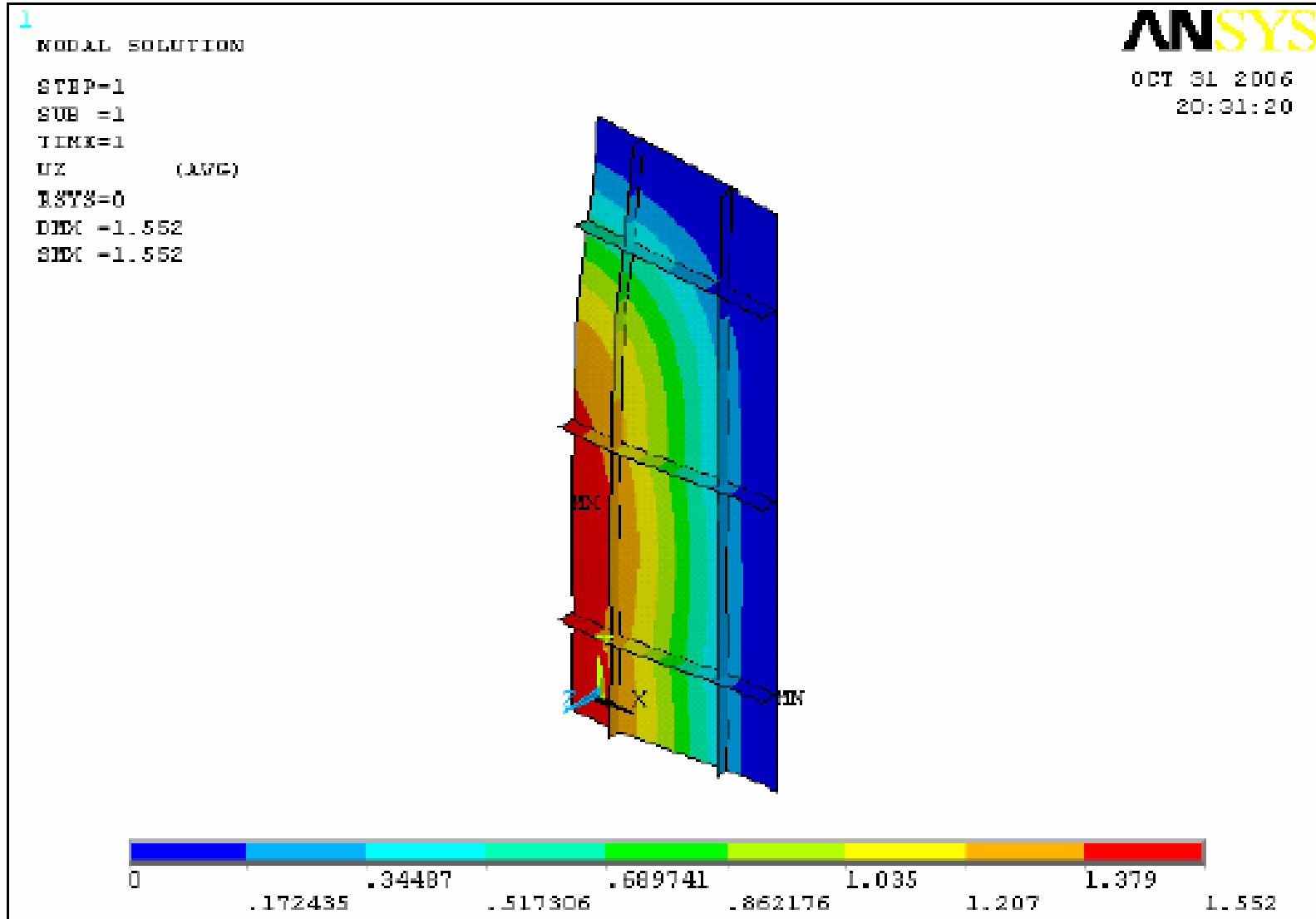
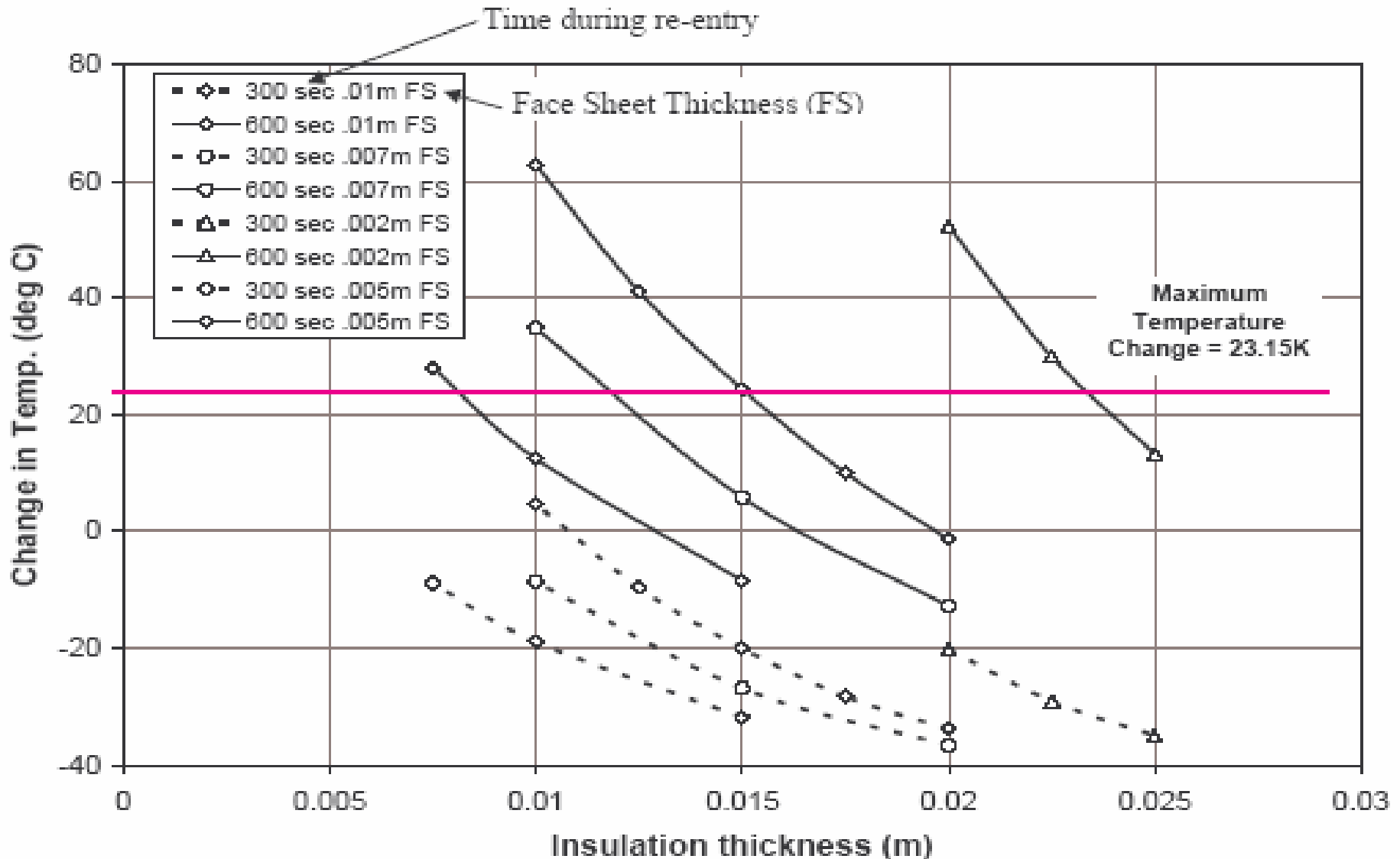

Figure 4: Schematic of the biaxial stiffened, single face sheet panel design.

Sample Student Work: Deflection of Pressure Loaded Stiffened Skin Structure



Sample Student Work: Parametric Study of Temperature Rise During Re-entry



Summary and Concerns - I

- Ansys FEM introduced
 - 5 lectures (75 minute periods)
 - Covered transient thermal analysis, shell structures, parametric modeling, buckling and stress analysis
- Students used FEM and closed form analysis methods to complete preliminary design
- Student reviews very positive

13. Overall, how does course compare with other technical courses you've taken at Cornell? 1=poorly, not educational; 5=excellently, extremely educational
--

4.60

Summary and Concerns - II

- Tutorials are a big help
- Students had trouble on problems for which we don't have tutorials
 - Difficult to get students up to speed with FEM in very short time.
- Following lecture via laptop based videoconferencing problematic – refresh rate of screen is slow. Must work slowly in order for students to see every menu that is opened up in ANSYS GUI.
- Lectures were recorded, which helped with above, but time consuming to scroll through recorded lecture and find exactly what you are looking for.
- Similar courses or projects may want to consider alternate modes of instruction.